

# VINYL LP CASE

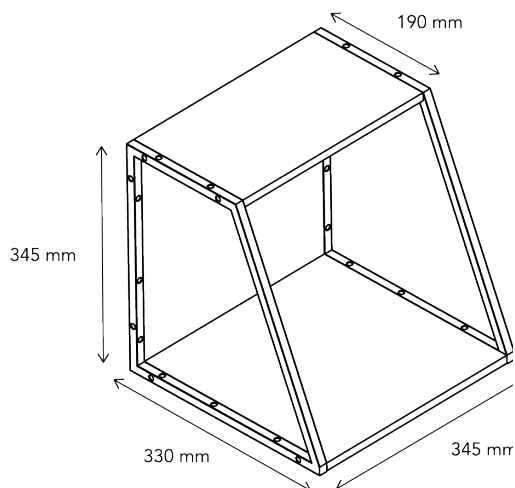

## DIMENSIONS



## MAX VINYLES QUANTITY



80 MAX TOTAL

## FINISH

 Bambou

## PRODUCT CODES

SKU : NORVINLPCBKBA  
EAN : 3700795180945

## DESCRIPTION

The Vinyl LP Case is an elegant storage unit that can be adapted to all tastes. Modular, it allows you to easily navigate through your favorite vinyl records in its tray position. In its shelf version, the Vinyl LP Case accommodates your entire collection in a modern, designer case.

Its very resistant metal structure and its bamboo case allow to store up to 80 vinyl records. The Vinyl LP Case can be mounted in both positions on the wall, giving you a wide range of possibilities for your interior. Each module can be stacked on top of the other to build a beautiful vinyl storage tower. Opt for 2 or 3 modules to create a real little vinyl storage unit next to your beloved turntable.

## DESIGN

Structure : Metal  
Shelves : Bamboo

## MAX LOAD

Shelf : 30 kg

## DIMENSIONS

External dimensions (W x H x D) : 345 x 345 x 330 mm

## PACKAGING

Delivered unassembled, plan required for assembly  
Quantity/box : 1  
Type : Brown box  
Dimensions (W x H x D) : 415 x 90 x 415 mm  
Gross weight : 3,5 kg  
Net weight : 2,9 kg

## ALSO AVAILABLE



VINYL LP R



## VINYL LP CASE

ASSEMBLY EXAMPLE